

DogScan

Ultrasound scanner



USER MANUAL

www.dog.draminski.com

ISO 9001 | 

Manufactured by:

DRAMIŃSKI S.A.

Wiktora Steffena 21

11-036 Sząbruk

Poland

phone: +48 89 675 26 00

e-mail: sales@draminski.com

www.dog.draminski.com

Dramiński S.A. has established and maintains a full quality management system in accordance with **EN ISO 9001**. The system is periodically audited by a notified body **TUV Rheinland LGA Products GmbH**, Tillystrasse 2, 90431 Nuremberg, Germany. It takes part in conformity assessment.

Declaration of conformity

Declaration of conformity can be obtained in our Sales Department:

Phone: +48 89 675 26 00

e-mail: sales@draminski.com

We wish you and users of this product a lot of success at working with this device. We believe that you will be able to achieve even better effects at work with our equipment.

DRAMIŃSKI S.A. will willingly deal with any comments and notices of our customers concerning the device and the user manual.

Please, call: **+48 89 675 26 00**

or send e-mails at: **sales@draminski.com**

Developed by DRAMIŃSKI S.A.

All rights reserved.

Copying without DRAMIŃSKI S.A. permission is prohibited.

CONTENT

INTRODUCTION	5
ELEMENTS OF EQUIPMENT	6
CONSTRUCTION OF THE SCANNER	6
TECHNICAL DATA	10
FRONT PANEL with a membrane keyboard	11
MENU STRUCTURE	14
EXAMINATION OF ANIMALS	18
BATTERY CHARGING	19
MAINTENANCE OF THE DEVICE AND THE HEAD	21
TROUBLESHOOTING	22
WARRANTY	23

Information about the user manual.

The user manual was developed to introduce technical properties of the device. It was written in a clear and comprehensible way in order to facilitate the use of the information provided in the guide.



Familiarizing yourself with the user manual cannot substitute even a basic ultrasound course. The operator should definitely undergo a proper ultrasound training or should have skills in testing pregnancy.

Certain parts of the user manual provide information about the construction of the device, all the accessories necessary to operate the device, preparation to work, basic functions and operating the ultrasound scanner.

Warnings and comments used in the guide.



In order to underline important information, the following means were used:

Warning! / Attention! / Bold text / Description of the schemes and figures.

Symbols used in the guide do not fully inform about dangers, that is why it is important to familiarize yourself with the instructions and follow them!

INTRODUCTION

Ultrasound equipment is widely used in breeding. It is very helpful in accurate testing of pregnancy at animals. Ultrasound scanning in B-mode, as a scanning method in real time, provides 2D images of tissue cross-sections. This is a very effective diagnostic method. Tissue structures are shown as points of light on the monitor. Their brightness is proportional to the amount of ultrasound waves reflected from the tissue. The tissues which reflect a great amount of the waves provide an image of bright or light-grey points. Liquids, in which the waves propagate without echo, are shown on the monitor as dark areas. In devices of this kind the quality of the obtained image depends on frequency of the waves emitted by the probe. The higher the frequency is, the better is the image resolution. However, when the frequency increases, the depth of penetration decreases, and the wave absorption and scattering coefficient increases almost linearly.

Ultrasound scanning is very efficient as far as pregnancy is concerned. A lot of research confirm that thanks to ultrasound equipment it is possible to detect pregnancy at dogs in the 23rd day. Carrying out diagnostics at an earlier phase of pregnancy does not give 100% certainty. A huge influence on effects of working with this ultrasound scanner has individual experience of an operator. Thanks to being small, ultrasound scanners have become standard equipment of veterinary doctors and breeders.

The **Dramiński DogScan** ultrasound scanner is a special device designed for quick, comfortable and reliable testing of dog's pregnancy. This is a portable ultrasound scanner with high performance battery pack (the pack of fully charged batteries enables 6 hours of continuous work).

The scanner is delivered in a specially designed transport case, which houses all the equipment necessary for proper operation of the device. This is a strong and solid case which protects your scanner against damage and guarantees comfort while transportation.

ELEMENTS OF EQUIPMENT

#	Name and description	Quantity
1	Ultrasound scanner with an LCD display and a keyboard	1
2	A 5.0MHz sector, abdominal probe	1
3	External Li-Ion battery pack 14.4V/3.1Ah	1
4	Special battery charger (with cables)	1
5	A neck strap	1
6	Transport case with foam insert	1

CONSTRUCTION OF THE SCANNER

The DRAMIŃSKI DogScan ultrasound scanner has a few main elements:

1. The body frame with a membrane keyboard and LCD LED display.
2. The ultrasound probe connected to the multi pin connector.
3. External multi-rechargeable battery pack.
4. Mains powered battery charger (110-240V/ 60Hz).

1. The body frame of the ultrasound scanner.

The body frame is made of high quality aluminum. At the rear face of the device there is a system for attaching a battery pack.

At the side of the body frame there is a 12-pin connector for the probe. The connector is covered with a special plug which protects it against moisture and dirt when the device is not operated. Description and location of the body frame elements are presented in further parts of the user manual.

Attention!

The ultrasound scanner is a solid device. However, during operation and transportation it should be handled with care in order not to damage the device. Protect it against strong impacts. The probe should be protected against getting wet or dirty.

5-inch LED back-lit LCD display is of high quality. It is characterized by wide viewing angles, excellent contrast, brightness and resolution, which guarantees excellent ultrasound images. An operator can adjust brightness of the monitor by choosing an appropriate position in the menu. The body frame has a 4-point system to install a neck strap. Functions and location of the membrane keyboard buttons and their description are presented in the figures in the further part of the user manual.

The ultrasound scanner is a technologically advanced device. Miniaturization and independent power supply guarantee full mobility and freedom even in the most difficult conditions.

View and description of the body frame elements

membrane keyboard with the display window

LED back-lit LCD monitor

silicone gasket

neck strap clip

aluminum body frame

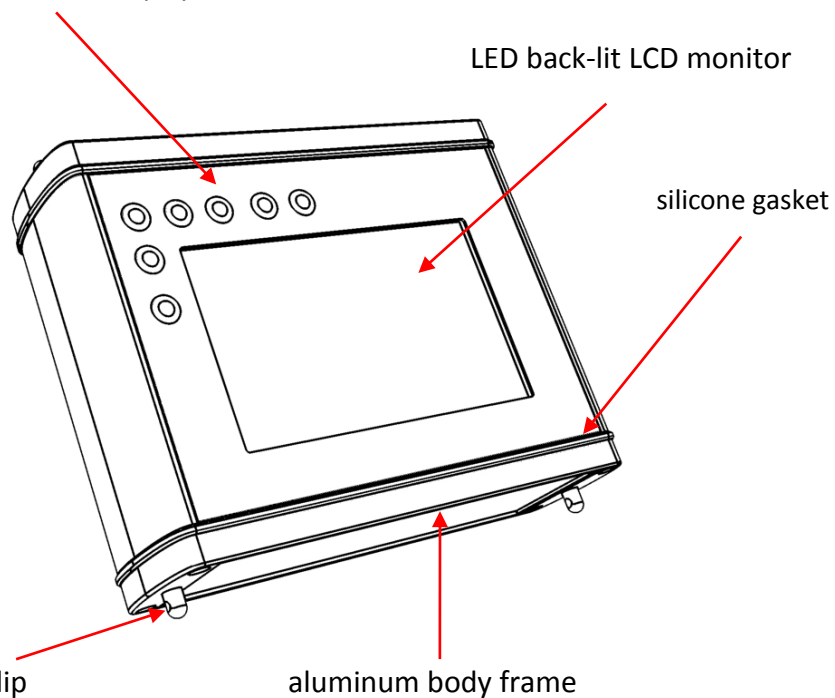

12-pin probe connector

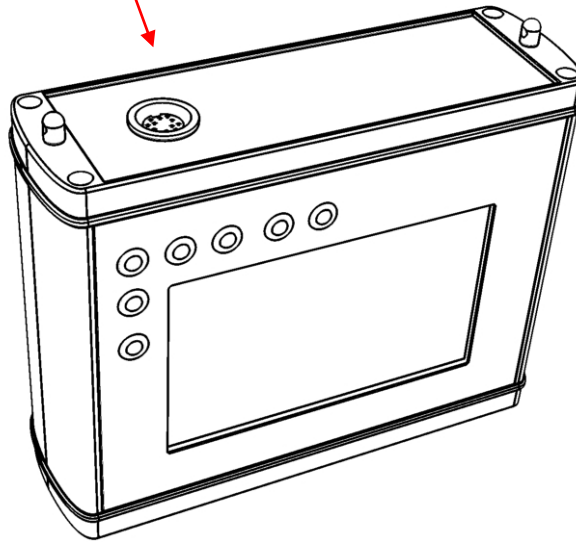

Rear view of the body frame without battery pack

battery pack connectors

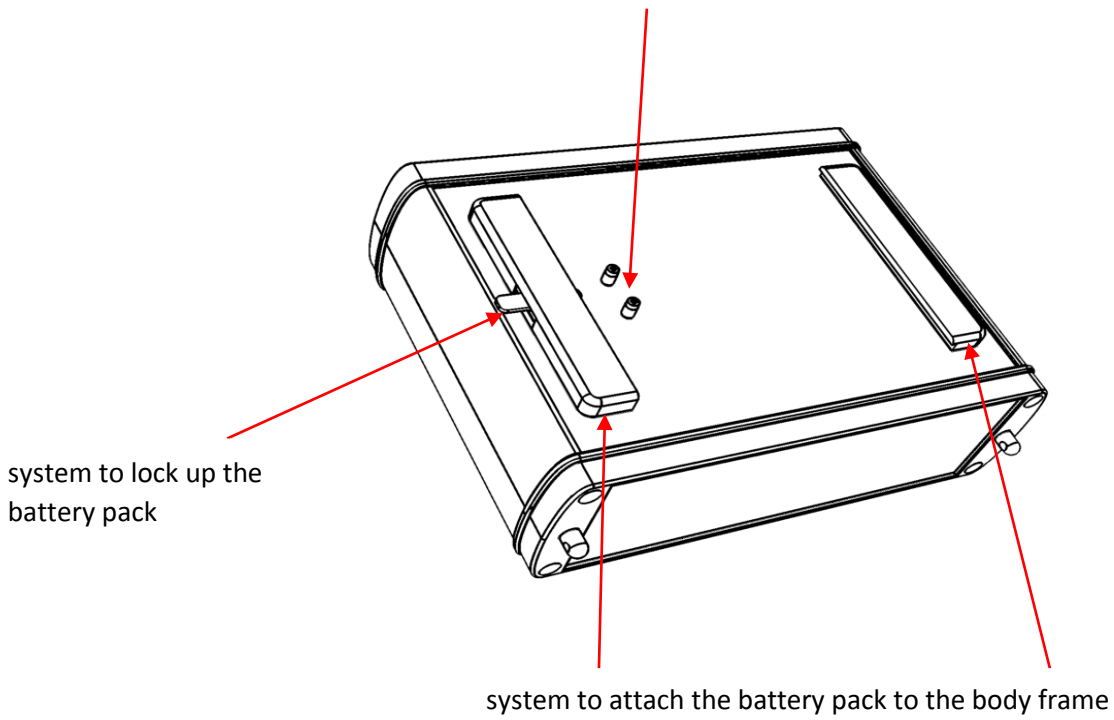

2. Ultrasound probe.

The **probe** (head) is a key element of the device. The **DRAMINIŃSKI DogScan** ultrasound scanner has one port with an abdominal probe.

5.0 MHz (3-7 MHz) sector abdominal probe, scan angle 90°



Attention! The probe is a complicated mechanical device which should be handled with care and protected against falling on the ground and strong impact. The head, under which there is a piezo ceramic element immersed in special oil, it should be protected against damages and scratches.

3. Batteries

Specially configured Li-Ion batteries make a pack with their own thermal fuse which protects from overheating during charging.

The battery pack frame body has a connector for the charger and special connecting pins in order to attach it to the ultrasound scanner. The pack is attached to the device from the bottom with the help of special hacks with a locking up system.

Li-Ion BATTERY PACK

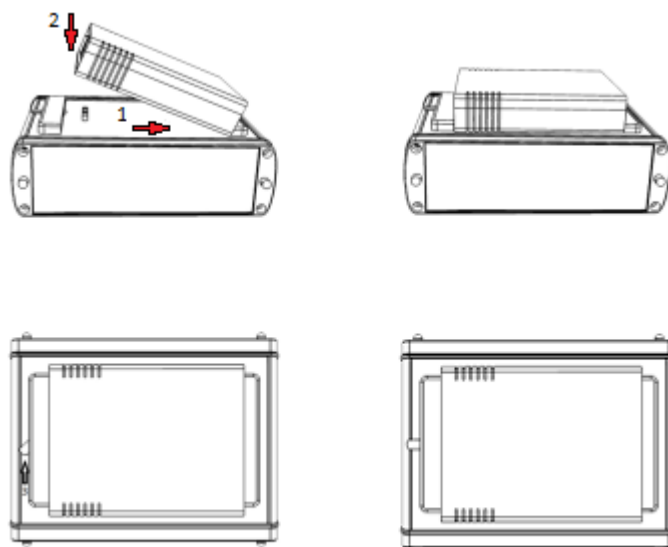

Fig. How to attach the battery pack

A lifespan of the batteries is about 500 charging cycles. The batteries have high capacity (3.1Ah), which guarantees 6 hours of continuous operation. Special precautions how to handle the lithium-ion batteries are described in the further part of the manual devoted to “**Battery charging**”.

4. Battery charger.

In order to charge the batteries use a specially designed battery charger powered from 110-240V/60Hz mains and equipped with cables and a control diode which indicates battery charge level.

Attention: Only original charger should be used to charge the battery pack.

More information how to charge the batteries and how to handle the charger is presented in the part devoted to “**Battery charging**”.

TECHNICAL DATA

<i>Imaging</i>	real time B-mode imaging
<i>Probe frequency</i>	3-7 MHz – central frequency - 5.0 MHz
<i>Probe type</i>	sector, mechanical, abdominal
<i>Probe frequency</i>	3-7 MHz – central frequency - 5.0 MHz
<i>Range (depth) of penetration</i>	max up to 25 cm
<i>Scan angle</i>	90° - abdominal probe
<i>Display</i>	5.0” LED back-lit LCD
<i>User interface</i>	membrane keyboard
<i>Power source</i>	external Li-Ion 14.4 V,3.1Ah battery pack
<i>Time of continuous operation</i>	6 hours (fully charge battery pack)
<i>Time of battery charging</i>	2 h 30 min
<i>Indicator of discharge of the battery</i>	automatic – sound signal and graphic indicator
<i>External dimensions</i>	length 17.5 x width 14.5 x height 6.0 cm
<i>Scanner weight</i>	1010g (without probe and battery pack)
<i>Probe weight</i>	250g
<i>Battery pack weight</i>	280g
<i>Operating temperature</i>	- 15°C до + 45°
<i>Storage temperature</i>	0°C до + 45°C

Attention!

If the storage temperature is less than 5°C, the probe has to be warmed before the use (for example, put it into warm water for about one minute).

Operating the scanner in extremely high and extremely low temperatures has a negative effect on its work and may cause damages.

FRONT PANEL with a membrane keyboard

1. Front panel.

The **DRAMIŃSKI DogScan**'s front panel has a 5-inch LCD display and a membrane keyboard used to control parameters of work during examination.

Function and location of keys are presented in the following figure:

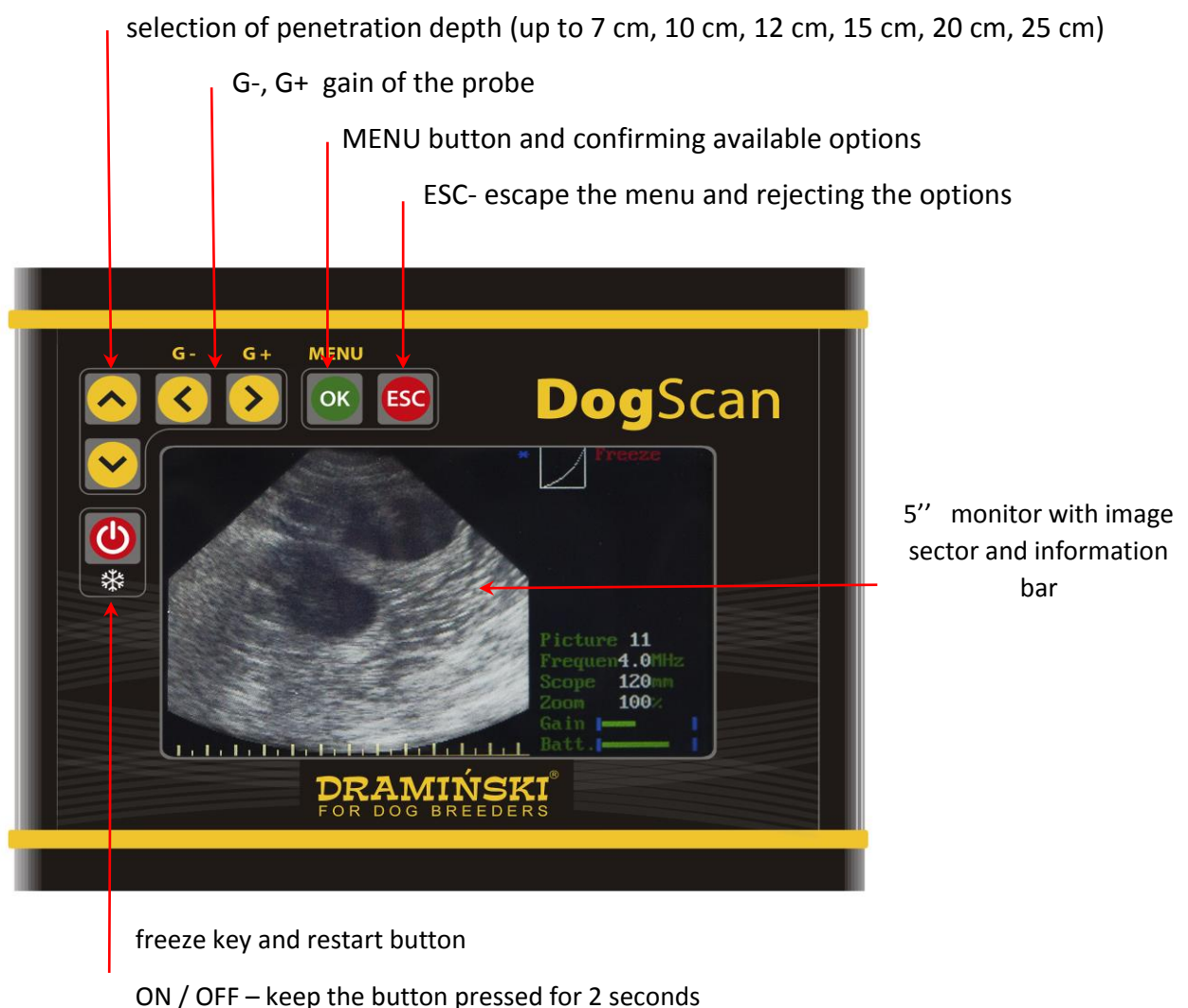

2. View of the screen.

Messages and information presented on the screen during operation of the device.

Exemplary view of the screen of the **DRAMINSKI DogScan** ultrasound scanner, description of messages and information:

Information **bar** presents current settings: probe gain level, frequency, scanning range, zoom, gamma level, freeze and battery level.

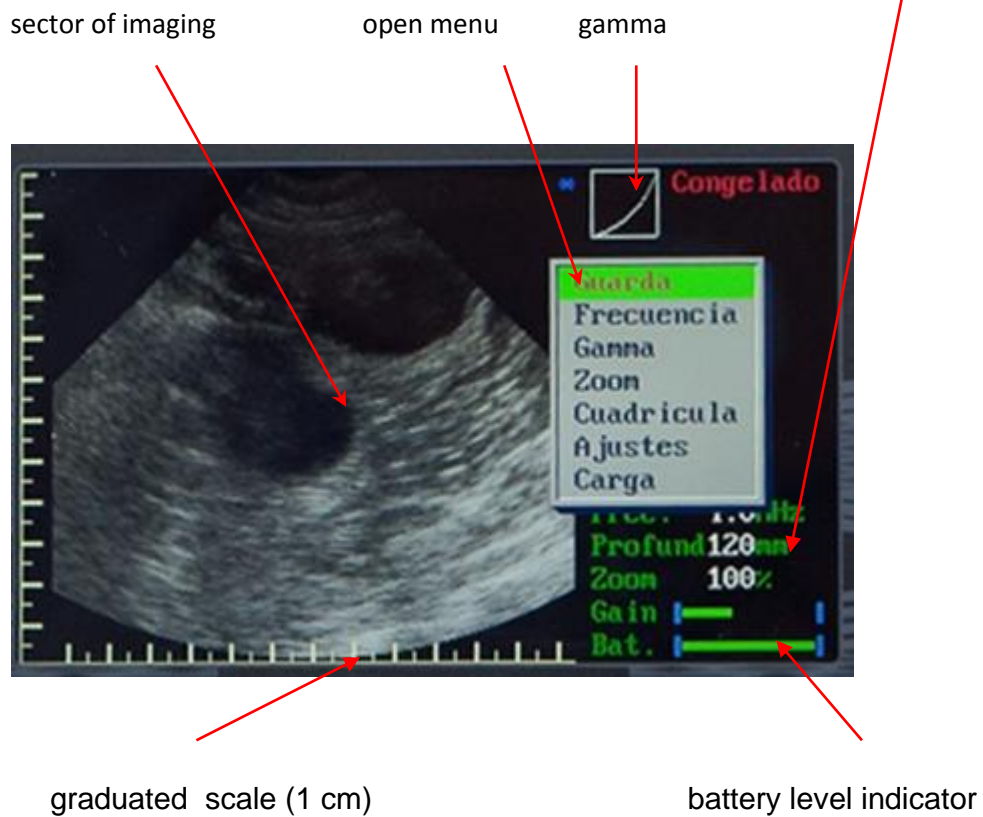

3. Connecting the probe.

Connect the round connector of the probe properly into the socket on the frame body and tighten it holding the metal part in order to guarantee full and proper connection of the probe's connector with the socket. The **DRAMIŃSKI DogScan** ultrasound scanner has one 12-pin connector used to connect the probe.



The probe properly connected to the ultrasound scanner

4. Attaching and checking the battery level

In order to check the battery level you should attach the battery pack to the device and switch it on. The information bar has a colour coded graphic indicator so that the user may learn how much time the device might be operated.

- Red colour – necessity to charge the pack, you can work for about 15 minutes.
- Yellow colour – you can work for about 1.5 h.
- Green colour – you can work min. 2 hours, 6 hours – if the battery pack is fully charged.

MENU STRUCTURE

1. How to navigate through the Menu.

Press „OK” to open the **DRAMIAŃSKI DogScan’s** menu. It is simple and it is easy to navigate through it. In order to select certain options and change the settings, use \wedge \vee buttons.

The selected position will be highlighted in green.

Press “OK” to confirm. Press “ESC” to escape (reject) the options.

Some options have messages (hints) which buttons can be used to set or change a selected parameter.

The menu has a few positions which enable setting the following parameters:

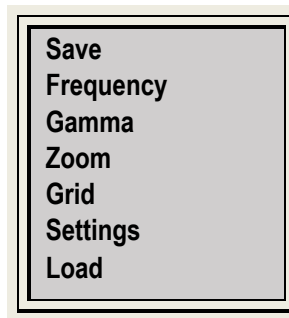

a) **Save.**

This option enables saving the image in the memory of the device (available when the image is frozen). The memory of the device can store 99 images. When this number is outranged, images are overwritten (No 100 replaces No 1, No 101 replaces No 2, etc.) Thanks to this function it is possible to store ultrasound images. They are available at any time, use the function **Upload** (e.g. the image of pregnancy at different stages of its development).

b) **Frequency. (This option is used to change the frequency of the signal from the head in order to optimize the image)**

This option enables frequency filtering generated from a broadband head in the range of 3.0 to 7.0 MHz. Frequency value is shown on the information bar.

c) **Gamma. (Option of changing the image in the range of a grey scale in order to optimize the image)**

This option enables changing the contrast and brightness of the image – gamma correction. Information bar presents a graphic curve. Gamma level (range from 1 to 7) can be changed using \wedge \vee buttons. This option is used to optimize the quality of an image depending on the type of

a carried out test and conditions in which the test is carried out. This regulation is possible in real time during scanning. When the gamma correction is set, it is necessary to adjust the gain level in order to obtain the best quality image.

d) Zoom. (This option enables magnifying the image)

This option can magnify the image from 100% to 120%, 140% and 160%. To regulate zoom, use \wedge \vee buttons, press “OK” to confirm.

e) Grid. (This option enables indicative measuring by showing the grid or the so called Viewfinder)

Having selected this option, it is possible to turn on / off the grid or the viewfinder using \wedge \vee buttons.

- **Grid:** Setting the grid in the form of horizontal and vertical lines. The grid’s graduation is 1 cm, it automatically scales when the depth of scanning changes.

- **Viewfinder:** This is an indicative measuring option which enables setting 1 mm graduated scale in the centre of the image.

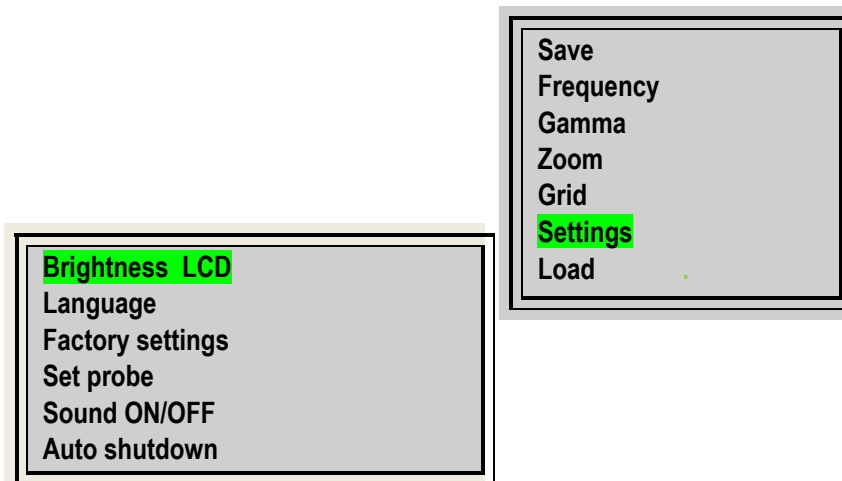

f) Settings. (Available for the user options of system changing or settings)

- **Brightness of the monitor. (Setting the level of brightness of the backlit LCD monitor)**

You can change brightness of the monitor in the range from 1 to 15.

- **Language. (This option enables changing the language of the system)**

Having chosen this option, a table with languages appears. Press “OK” to confirm the language. The system automatically switches to a selected language version.

- **Factory defaults. (This option enables restoring factory settings)**

When you confirm this option, the system shows a message: **“To restore Factory settings, Press OK”**. When you press OK, the system turns off and when it restarts, it turns to factory settings. This option should be used only in a situation of a malfunction or in connection with difficulties in returning to optimal settings. When this operation is done, the system switches to the English language version.

- **Head settings.**

This option is rarely used. It should be carried out by the service or in a case when mechanical displacement of the index takes place after the head has experienced a strong impact or has fallen on the ground. Typical symptom of the displaced index is a slightly blurred image. When this option is selected, the following message will appear on the information bar: **Head settings**. It enables setting the numerical value (index) stabilizing the image from the probe. When the image is stabilized, press ‘OK’ to confirm the shown value.

- **Sound.**

This option enables turning off or activating the sound which signals pressing the keys. It can be helpful when testing timid animals.

- **Automatic OFF. (This option enables automatic switching off of the device)**



An operator can choose time after which the device automatically switches off after the last key press, i.e. 2, 5, 10, 20, 30 minutes or ----- (the device will not switch off automatically). This option allows save the battery, for example, when the device is left unattended.

Attention! The ultrasound scanner switches off after a pre-set period of time if the probe is connected to the body.

g) Upload.

After having chosen this function, it is possible to view images saved in the memory of the scanner. When you press **OK**, the last ultrasound image is shown automatically. With the help of \wedge \vee buttons it is possible to choose the image we would like to view. The screen shows the following information: image No, probe frequency, range (depth) of penetration, zoom and gain which were pre-set at the moment of the test, freezing and saving the image to the memory.

FREQUENTLY USED FUNCTIONS

<p style="text-align: center;">Freeze</p>		<p>The image freezes when you press this button, the information bar shows the message “Frozen”.</p> <p>In order to return to scanning, press this button again. Notice! If you hold this button for more than 2 seconds, the device switches off. This is a basic function used during testing animals.</p>
<p style="text-align: center;">Gain regulation</p>		<p>Buttons G – and G + enable regulating gain level in the nearest and furthest area from the head. Gain levels are regulated in order to optimize quality and readability of an image depending on the type of testing, kind of animal or conditions in which the test is carried out.</p>
<p style="text-align: center;">Changing the depth of penetration</p>		<p>The range of penetration (depth of scanning) is set with the help of ^ , v buttons. The depths should be adjusted in order to obtain the best quality image depending on the type of the test and its conditions.</p> <p>Maximum depth for abdominal probe is 25 cm.</p> <p>The value of the pre-set range is shown on the information bar. In the bottom part of the screen and at the side of the imaging sector there is a scale which graduation is 1 cm. It automatically scales when the depth of scanning changes.</p>

EXAMINATION OF ANIMALS

Before you start working, prepare the device and the accessories.

1. Connect the battery pack.
2. Connect the probe.
3. Switch on the device and check the battery level. Fully charged batteries enable 6 hours of continuous work.
4. You need special gel to carry out testing (please, use gels which are recommended for ultrasound scanning, make sure that the gel has an adequate certificate of authorization).

Enough amount of gel improves penetration of signals and enables obtainment of proper and more readable images.

Before you start working, make sure that you have enough of gel to carry out all the examinations that you have scheduled.

If an animal has a lot of fur, it is recommended to use diluted alcohol in order to obtain a better image. A number of factors influences the quality of an image, among them: preparation of the animal, a place where the head is attached, the angle of penetration (the way the probe is attached), amount of gel and experience of an operator.

A neck strap attached to the scanner enables regulation of its length and angle of inclination of the device. Regulation has to be carried out before tests according to the operator's needs. During the test the keyboard is used to set the best parameters of work depending on specific conditions.

BATTERY CHARGING

Li-Ion battery pack is multi-rechargeable. Battery lifespan depends on the way it is exploited. It is recommended to use the pack in full cycles, it means – full charge, full discharge.

DRAMINSKI BATTERY PACK's lifespan is about 500 full charge cycles.

Thanks to the use of high-capacity batteries it is possible to work continuously for about 6 hours.

At the bottom of the **DRAMINSKI DogScan's** screen there is a graphic symbol which indicates the battery level. If the strip becomes shorter and its colour changes from green to yellow, it means that the battery is discharging and you may work for about 1 hour 30 minutes until it gets very low. If you leave the scanner turned on, the battery gets fully discharged and the device automatically switches off, which is signaled by a message in the middle of the screen.

Charging the **DRAMINSKI BATTERY PACK (3.1Ah)**.

Use the original charger which parameters guarantee proper charging to charge the battery pack.

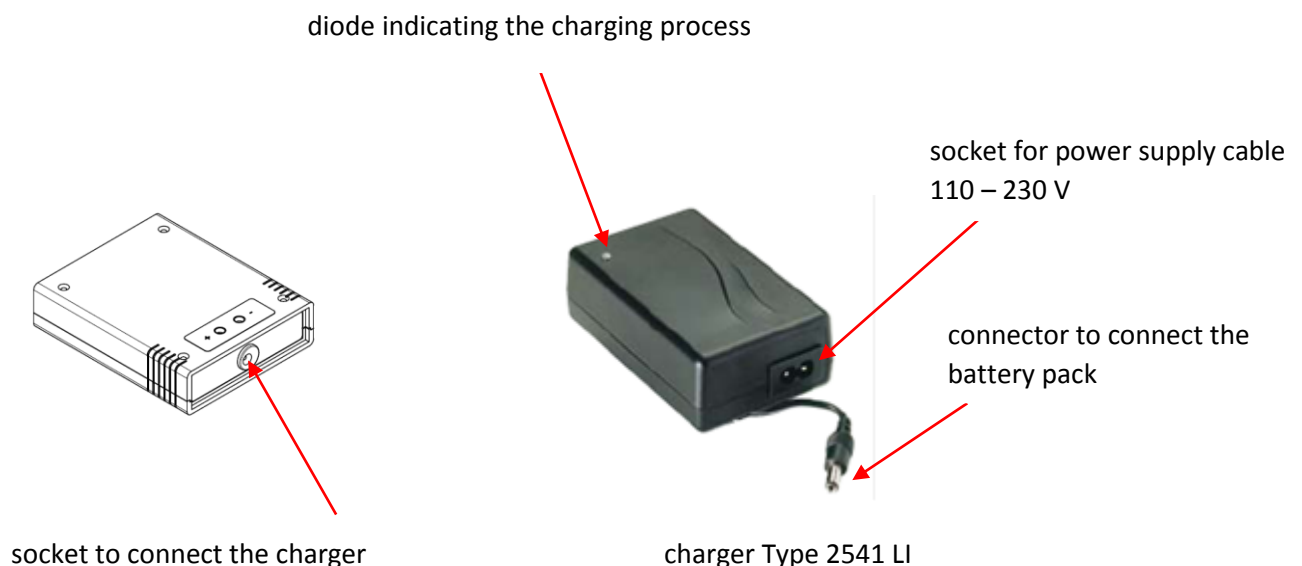

In order to charge the battery pack you have to do the following:

- a) switch off power supply (ON/OFF) of the ultrasound scanner and disconnect the pack,
- b) connect the charger's cable to the socket in the pack,

- c) plug in the charger to the mains 110-230 V / 50 Hz,
- d) observe the charger's diode – if it changes its colour from red (discharged battery pack) to green, it means that the pack is fully and properly charged.

Charging of a fully discharged battery lasts about 2 hours and 30 minutes. When the battery pack is fully charged, the charger automatically stops charging.



Warning! It is forbidden to perform any unauthorized repairs or dismantle the device by an unauthorized person. The battery pack should be charged with the original charger supplied by the manufacturer.

Taking into account the user's safety and the device's durability, the charger should not be used in wet and humid places. Before the use, check the charger's main elements (including cables) for any damages.

In the case if you find any failures, you should immediately pull out the mains plug and replace the damaged part contacting the manufacturer.

Attention! The charger is an auxiliary device used to charge the battery pack. It is not a part of the **DRAMINŃSKI DogScan** ultrasound scanner which should be used during testing.

Attention! If you connect the charger to the battery pack connected to the ultrasound scanner, the power supply automatically stops and you cannot carry out any tests.

Safety precautions for lithium-ion batteries.

- It is forbidden to dismantle the battery pack which makes an integrated part.
- Do not short-circuit the connectors on the battery pack frame body with metal objects.
- It is forbidden to through the battery pack to fire or heat it.
- It is forbidden to impact on the battery pack mechanically or through it out.
- If you notice a leak of electrolyte, stop using the battery pack.
- Avoid getting liquid in the battery pack, it may cause a sudden increase of temperature of the batteries and a danger.
- You should not leave the battery pack at high ambient temperature, for example, inside the car in direct sunlight, or near heat sources. Failure to observe these obligations may lead to electrolyte leakage, damaging the battery or shorten its durability.

- The batteries should be charged at ambient temperature of 0 °C to 40 °C. Charging the battery in a different range of ambient temperature may cause danger or lasting harm to the pack.
- If you have problems with charging after a long period of use (about 500 cycles), you should replace the battery pack.
- Waste batteries should be recycled in accordance with the current provisions.

MAINTENANCE OF THE DEVICE AND THE HEAD

The device can get strongly contaminated, including infectious agents. When you finish work, immediately clean the device with soft, wet cloth or paper towel with mild detergent solution. While cleaning, protect the socket against getting wet, use a special plug.

The surface of the device should be disinfected by chemicals used for disinfection of veterinary equipment.

Attention! The ultrasound probe should be disinfected after each use.

If necessary, after wet cleaning the probe and the ultrasound scanner should be dried with a soft paper towel.

The carrying case should be cleaned externally with water and detergent. The foam insert should be vacuumed regularly and cleaned with water and a mild detergent. A disinfectant solution, e.g. Virkon S, may be used for disinfection. Before using the carrying case, make sure that the foam insert is completely dry.



Warning! – It is forbidden to use aggressive, concentrated and abrasive chemicals. These chemicals can easily damage the surface of the probe, the monitor and the surface of the frame body.

Protect the probe socket against getting wet while cleaning it.

The user of the ultrasound scanner should regularly perform maintenance service. This will guarantee high level of safety and durability in exploitation.

Operational and technical notes.

Prepare the device and accessories before work.

- Switch on power supply and check the battery level.
- Many factors influence the quality of the obtained images, among others: the place where the head is attached, the plane of penetration (the way the head is attached), amount of gel, and of course, experience and skills of an operator.
- During the test the keyboard is used to pre-set the best parameters of work in specific conditions. You should regulate the gain. The device “remembers” the last gain settings for specific depths of scanning. Use the function of frequency changing, this will help obtain more readable images in the area of testing.

Protect the head of the probe and the cable against mechanical damages. Remember about:

- Proper installation of the probe cable. Improperly installed or twisted cable may cause damage to the wire.
- Proper installation of the probe and the cable in the case. Avoid bending the cable, it can lead to damaging the wire.
- Proper and safe storage of the probe.

TROUBLESHOOTING

Abnormal behaviour of the device	PROBLEM SOLVING
No power supply – the device won't start.	<ol style="list-style-type: none">1. Check if the battery pack is properly connected.2. Check the device with another battery pack, if possible.
Unclear image, or lack of image	<ol style="list-style-type: none">1. Check if the head is properly connected or check the head's settings (Menu: Set the head).
Image is too bright or too dark	<ol style="list-style-type: none">1. Check gain, gamma, MHz settings or return to default settings.
No charging signal in the charger	<ol style="list-style-type: none">1. Check the connection of the cables.2. Check the mains.
Battery works too short	<ol style="list-style-type: none">1. The battery is not fully charge.2. Ambient temperature is too low.3. The battery is worn out (typical symptom which follows from its construction and operational rules)

If none of these actions helps, contact the service department of DRAMIŃSKI

S.A. phone +48 89 675 26 00 or e-mail: sales@draminski.com

WARRANTY

The manufacturer gives 24-month warranty. We guarantee its flawless operation if the device is used in accordance with this user manual.

The battery pack has 6-month warranty.

If a failure occurs, which was not caused by the user, the manufacturer is obliged to repair the device within 14 working days from the delivering of the equipment to the service centre and to return the repaired equipment to the user at the expense of the manufacturer.

Mechanical damages, or damages caused by improper use, storage or unauthorized repairs are not covered by the warranty.

The warranty comes into force on the basis of proof-of-purchase (invoice). In order to submit a complaint, inform DRAMIŃSKI S.A. about any defects immediately since you noticed them; in any case, however, before the expiry of the warranty period.

To submit a warranty claim, the following steps must be taken:

1. Notify DRAMIŃSKI S.A. of the device malfunction immediately after it occurs.
2. Send the device to the Service Department (no later than before the warranty expiration date) or deliver it in person together with the proof of purchase, which should include the seller's and purchaser's details, the date and place of purchase, the device name, and its serial number.
3. A description of the malfunction must be enclosed with the device sent to the Service Department to ensure efficient diagnosis and repair of the damage:
 - Before shipping, the ultrasound device, carrying case, and all included accessories must be cleaned and disinfected (*in accordance with the Cleaning and Disinfection section),
 - Please pay particular attention when packaging the device to ensure that it is properly secured, as the manufacturer shall not be held liable for any damage incurred during transport.

Warranty is given by:

DRAMIŃSKI S.A.

Wiktora Steffena 21, 11-036 Sząbruk, POLAND

phone +48 89 675 26 00

e-mail address: sales@draminski.com

draminski.com/dog-breeding-equipment



www.draminski.com

Wiktora Steffena 21, 11-036 Sząbruk, Poland
tel. +48 89 675 26 00
e-mail: sales@draminski.com